



## **Solutions for blistered medications**

Aids for the storage and distribution of blistered medications in hospitals and care homes



## Your expert for medication solutions

Wiegand has been developing convincing solutions for supplies and medication logistics for over 45 years. We offer tailor-made solutions - from central storage to the furnishing and equipping of ward rooms and pharmacies to the individual distribution of medicines at the patient's bedside. Wiegand does not offer standard solutions, but the right solution for every requirement.

### Optimal storage and distribution of blistered medicines

The externally supplied and blistered medication significantly reduces the workload for the nursing staff. The challenge comes in the storage and delivery of the medication in blister rolls to the residents. Wiegand offers you a comprehensive range of aids to simplify these processes.

Wiegand's blister trolleys are tailored to the medication process with medication blisters and offer space for blister rolls as well as for additional medications such as creams, drops and supplementary materials.



### Swiss quality products

As a family business, Wiegand will continue to rely on Switzerland as a production location in the future. The FlexLine trolleys are manufactured in the company's own production facility. Each FlexLine trolley is individually manufactured for you from high-quality and durable materials.

## Easy storage, arrangement and distribution of blistered medicines

Wiegand offers a diverse range of aids for the storage and distribution of blistered medicines. Wiegand products simplify workflows and help to increase patient safety. The Wiegand system supports the distribution of blistered and other medicines in a simple, practical, and safe way.

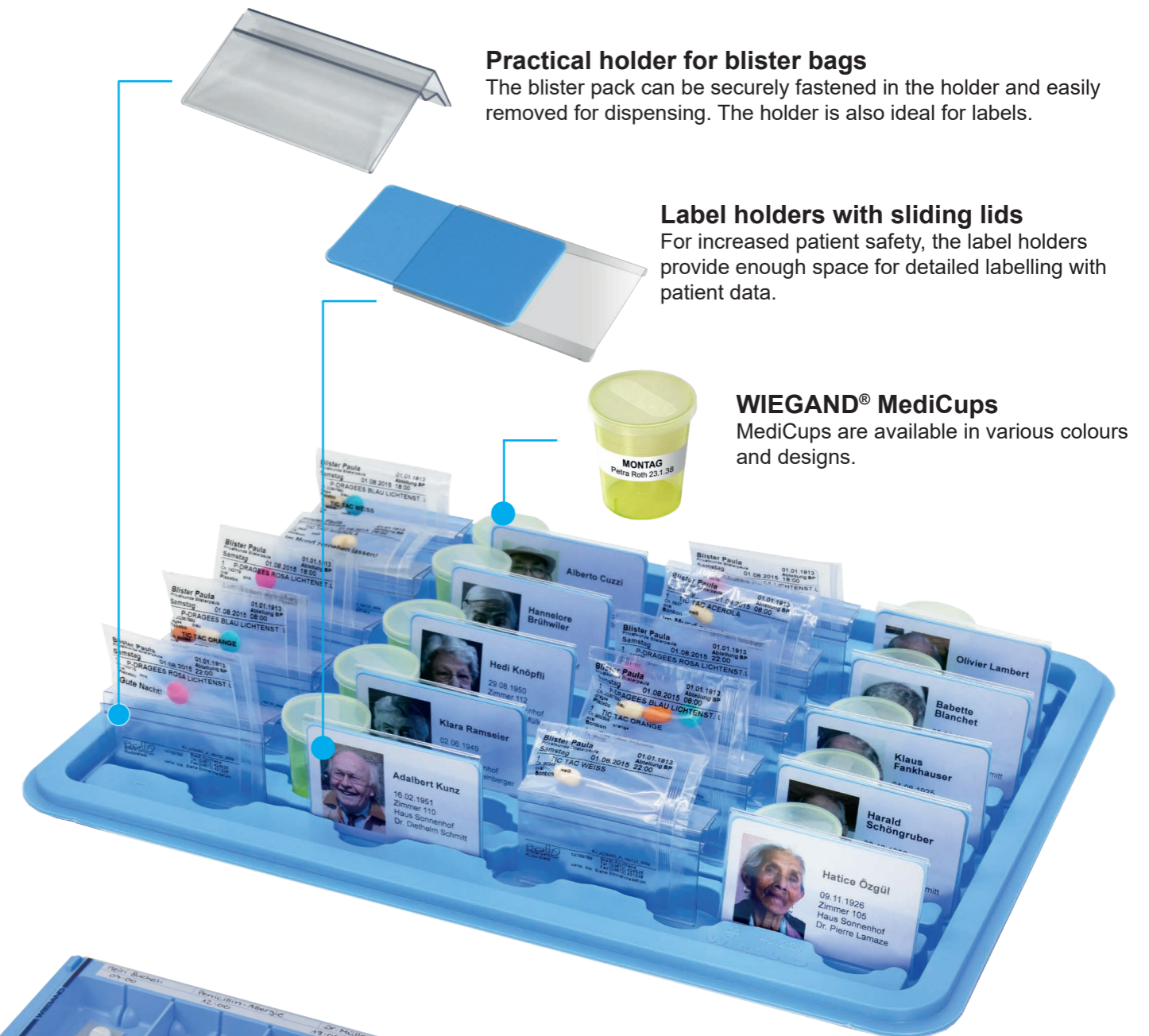

### Practical holder for blister bags

The blister pack can be securely fastened in the holder and easily removed for dispensing. The holder is also ideal for labels.

### Label holders with sliding lids

For increased patient safety, the label holders provide enough space for detailed labelling with patient data.

### WIEGAND® MediCups

MediCups are available in various colours and designs.



### WIEGAND® MediDispenser

WIEGAND® MediDispensers are ideal for storing reserve or additional medications. MediDispensers can also be used when therapies are changed or are not yet available in packet strip blisters.

### Dispenser Marker

The Dispenser Marker is a permanent ink pen with special eraser. The fine tip is suitable for writing on medicine dispensers, medicine cups, medicine containers and labels.



# WIEGAND® Starter-sets blistering

The starter sets support the distribution process of blistered pills in blister packs. The set includes one label holder per resident, a practical holder for the blister pack and a MediCup for dispensing the de-blistered pills. The necessary patient data and the patient picture can be printed on the enclosed labels and the labels can be stuck on the label holders provided. This increases medication safety, as an additional visual check can take place through the patient picture. The enclosed MediDispenser can be used for the medication of new patients.

## Description

### Starter-set blistering S

The Starter Set Blistering S is ideal for the distribution of medication in blister pack for up to 5 residents. The distribution tray has 10 grooves and 30 positions for MediCups. Dimensions distribution tray: 260x300mm

#### Set consisting of:

- 1 distribution tray (S)
- 50 MediCups
- 100 lids for MediCups
- 5 holders for blister packs
- 5 Label holders with sliding lids
- 5 Sheets of label for patient picture and data
- 1 MediDispenser 341/349 with flexible subdivisions
- Flyer: Informations for rest and nursing homes



## Article No.

600.301.211.de 1 Starter-set blistering S

## Description

### Starter-set blistering M

The Starter Set Blistering M is ideal for the distribution of medication in blister pack for up to 10 residents. The distribution tray has 10 grooves and 50 positions for MediCups. Dimensions distribution tray: 400x300mm

#### Set consisting of:

- 1 distribution tray (M)
- 50 MediCups, red
- 50 MediCups, yellow
- 100 lids for MediCups
- 10 holders for blister packs
- 10 Label holders with sliding lids
- 10 Sheets of label for patient picture and data
- 1 MediDispenser 341/349 with flexible subdivisions
- 1 Dispenser Marker, waterproof foil pen
- 1 MediSplitter WIEGAND®, tablet divider
- Flyer: Informations for rest and nursing homes

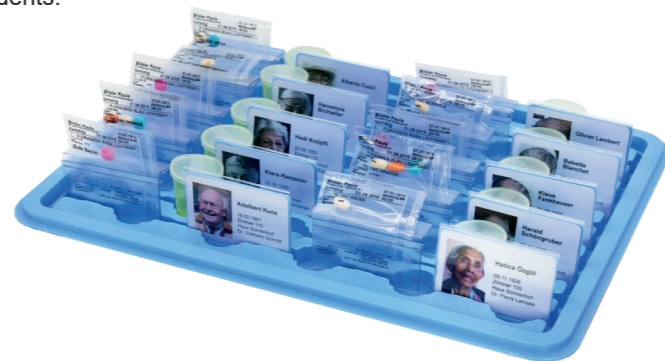

## Article No.

600.301.221.de 1 Starter-set blistering M



## Description

### Starter-set blistering L

The Starter Set Blistering L is ideal for the distribution of medication in blister pack for up to 16 residents. The distribution tray has 16 grooves and 80 positions for MediCups. Dimensions distribution tray: 450x400mm

#### Set consisting of:

- 1 distribution tray (L)
- 50 MediCups, red
- 50 MediCups, yellow
- 100 lids for MediCups
- 16 holders for blister packs
- 16 Label holders with sliding lids
- 10 Sheets of label for patient picture and data
- 1 MediDispenser 341/349 with flexible subdivisions
- 1 Dispenser Marker, waterproof foil pen
- 1 MediSplitter WIEGAND®, tablet divider
- Flyer: Informations for rest and nursing homes



## Article No.

600.301.241.de 1 Starter-set blistering L



## Description

### Starter-set blistering XL

The Starter Set Blistering XL is ideal for the distribution of medication in blister pack for up to 22 residents. The distribution tray has 22 grooves and 110 positions for MediCups. Dimensions distribution tray: 400x600mm

#### Set consisting of:

- 1 distribution tray (XL)
- 50 MediCups, red
- 50 MediCups, yellow
- 100 lids for MediCups
- 22 holders for blister packs
- 22 Label holders with sliding lids
- 10 Sheets of label for patient picture and data
- 1 MediDispenser 341/349 with flexible subdivisions
- 1 PharmaBox small, small container with sliding lid
- 1 Dispenser Marker, waterproof foil pen
- 1 MediSplitter WIEGAND®, tablet divider
- Flyer: Informations for rest and nursing homes



## Article No.

600.301.251.de 1 Starter-set blistering XL



# Storage and distribution of medication in blister packs

Blistering is a variant of external preparation. This involves the mechanical preparation of prescribed tablets by a blister machine or device. The blister packs can be easily integrated into existing Wiegand distribution systems.

The hygienic and durable Wiegand BlisterBoxes store a patient's blister pack for one or two weeks and can be easily unrolled and detached.

**Description** **BlisterBox duro**

- Large dispenser for the storage and distribution of medicines blistered in a packet strip
- The BlisterBox duro is dishwasher safe, but can also be easily cleaned by hand
- Dimensions: 87x127x120 mm

**Article No.** 150.322.001 1 BlisterBox duro  
150.322.001-54 Pack of 54 pcs. BlisterBox duro



**Description** **BlisterBox Compact**

- Large dispenser for the storage and distribution of medicines blistered in a packet strip
- The BlisterBoxes are delivered unfolded
- Standard soap detergents can be used for cleaning
- Dimensions: 78x128x107 mm

**Article No.** 312T 1 BlisterBox Compact  
312T-100 Pack of 100 pcs. BlisterBox Compact



**Description** **BlisterBox Large**

- Large dispenser for the storage and distribution of medicines blistered in a packet strip
- The BlisterBoxes are delivered unfolded
- Standard soap detergents can be used for cleaning
- Dimensions: 78x162x139 mm

**Article No.** 311T 1 BlisterBox Large  
311T-100 Pack of 100 pcs. BlisterBox Large



# Wiegand distribution trays

Whether you're working with MediDispenser, blister packs or MediCup at the moment – the Wiegand distribution trays lend themselves to a wide range of uses. The low weight of the distribution tray and the flexible organisation support the medication dispensing process. Thanks to the clear overview this provides, administration errors are easily avoided.



**Description** **Distribution tray (S)**

- Stackable distribution tray with 10 grooves and 30 positions for MediCups
- Suitable for Wiegand trolleys with trays
- Dimensions: 260x300 mm

**Article No.** 140.211 1 distribution tray (S)  
140.211-45 Pack of 45 pcs. distribution trays (S)



**Description** **Distribution tray (M)**

- Stackable distribution tray with 10 grooves and 50 positions for MediCups
- Suitable for Wiegand trolleys with trays
- Suitable for storage in ISO-A cabinets
- Dimensions: 400x300 mm

**Article No.** 140.221 1 distribution tray (M)  
140.221-18 Pack of 18 pcs. distribution trays (M)



# Easy storage and presentation of blistered medicines

Wiegand offers a diverse range of aids for the storage and distribution of blistered medicines. Wiegand products simplify workflows and help to increase patient safety. The Wiegand system enables the distribution of blistered and other medicines in a simple, practical and safe way.

Wiegand's hygienic and durable BlisterBoxes are high quality and robust and meet the high demands of nursing staff.

## Description Holder for blister packs or labels

- Suitable for attaching tube blisters
- Pluggable on WIEGAND distribution trays, FlexModul trays/baskets
- Dimensions: 75x40 mm

**Article No.** 500.240XO.075 1 holder for blister bags or labels



## Description Label holder with sliding lid

- Label holder as a carrier for patient data during medication dispensing with a Wiegand distribution tray
- Fits labels 510.13A4 and 510.13
- Dimensions: 77x55 mm

**Art. No.** 15/15SD-50 50 pcs. label holder  
15/15SD-500 500 pcs. label holder

**Accessories** 15SD.50 Spare sliding lids, 50 pcs.  
510.13A4 Label for patient image and data  
510.13 Label for medication



## Description PharmaBox

- Ideal für the storage of blistered medicines and various auxiliary material
- With a universal holder (art. 16), it can easily be placed on a distribution tray
- Incl. sliding lid, transparent
- Dimensions: 134x72x30 mm

**Art. No.** 111/119.0-10 10 pcs. PharmaBox  
111/119.0-400 400 pcs. PharmaBox

**Accessories** 119.40 Additional sliding lids, 40 pcs.  
119.400 Additional sliding lids, 400 pcs.



## Description Universal holder for distribution trays

- Universal holder for small containers and PharmaBoxes for mounting on Wiegand distribution trays
- Self-adhesive
- Dimensions: 30x65 mm

**Art. No.** 16-1 1 pc. universal holder  
16-100 100 pcs. universal holder

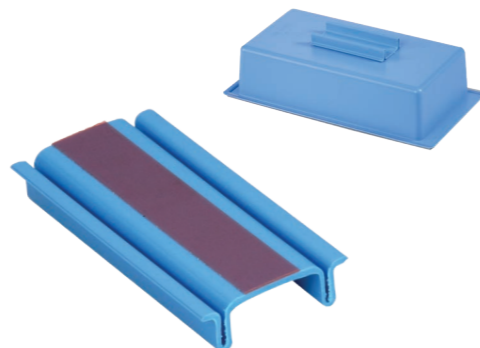

# Medication aids

Wiegand's wide and varied range offers everything needed for medication preparation, from pill processing aids to MediCups and storage boxes. Choose your suitable aids from our well-rounded range.

## Description WIEGAND® PillCrusher Professional

- With this robust pill crusher, tablets can be processed hygienically and without the use of force to form a ready-to-use powder.
- Durable, easy to clean and maintenance-free
- Dimensions: 285x85x65 mm

**Article No.** 202.95.01 1 PillCrusher Professional  
202.95.01-6 Pack of 6 pcs. PillCrusher Professional



## Description PillCrusher Pouches for single use

- The strong ribbed reinforced PillCrusher Pouches for single use prevent tearing, despite heavy pressures while crushing.
- With rounded corners so that the powder can be poured out easily
- Dimensions: 50x120 mm

**Article No.** 202.95.11-50 Pack of 50 pcs PillCrusher Pouches  
202.95.11-1000 Pack of 1000 pcs. PillCrusher Pouches  
202.95.11-8000 Pack of 8000 pcs. PillCrusher Pouches



## Description PillCrusher

- PillCrusher for the crushing and pulverisation of tablets
- Tablets can be processed directly in the medicine cup
- Can be cleaned in the dishwasher
- Dimensions: 70x105 mm (Ø x H)

**Article No.** 202.097.001 1 Pillcrusher  
202.097.001-10 Pack of 10 pcs. PillCrusher



## Description MediSplitter

- Handy tablet divider for halving oder quartering tablets
- The tablet can be easily positioned for division with the stainless steel blade
- Once split, the tablet falls into the storage container
- Dimensions: 85x35x25 mm

**Article No.** 96T 1 MediSplitter  
96T-24 Pack of 24 pcs. MediSplitter



**Description** **Disposable MediCup ECO**

- 40% less resource consumption
- With graduation up to 30 ml
- Suitable for dispensing both oral medication and tablets
- For single use, not washable
- Available in bars of 90 pcs. or in boxes of 9'000 pcs.
- Dimensions: 38x42 mm (Ø x H)



<b>Art. No.</b>	200.81.1	transparent	200.81.4	red
	200.81.2	yellow	200.81.5	green
	200.81.3	blue		

**Accessories** 200.82 Lid for MediCups ECO

**Description** **Lid for MediCup ECO**

- Lid fits on MediCup ECO
- Colour: white
- Dimensions: Ø 38 mm

<b>Art. No.</b>	200.82-100	100 pcs. lids
	200.82-9000	9'000 pcs. lids



**Description** **Disposable MediCup Light**

- With graduation up to 30 ml
- Suitable for dispensing both oral medication and tablets
- For single use, not washable
- Available in bars of 80 pcs. or in boxes of 4'800 pcs.
- Dimensions: 38x42 mm (Ø x H)



<b>Art. No.</b>	200.77.1	transparent	200.77.4	red
	200.77.2	yellow	200.77.5	green
	200.77.3	blue		

**Accessories** 200.78 Lid for MediCups Light

**Description** **Lid for disposable MediCup Light**

- Lid fits on disposable MediCup Light
- Colour: white
- Dimensions: Ø 38 mm

<b>Art. No.</b>	200.78-100	100 pcs. lids
	200.78-4000	4'000 pcs. lids



**Description** **MediCup reusable**

- With graduation up to 25 ml
- Suitable for dispensing both oral medication and tablets
- Available in bars of 50 pcs. or in boxes of 4'000 pcs.
- Dimensions: 35x40 mm (Ø x H)



<b>Art. No.</b>	71.1	transparent	71.4	red
	71.2	yellow	71.5	green
	71.3	blue		

**Accessories** 72 Lid for MediCups reusable

**Description** **Lid for MediCup reusable**

- Writable lid fits on MediCup reusable
- Colour: transparent
- Dimensions: Ø 36 mm

<b>Art. No.</b>	72-100	100 pc. lids
	72-2000	2'000 pcs. lids



**Description** **Dispenser for MediCups**

- Dispenser for MediCups
- For mounting on wall or FlexLine trolleys
- Without rod for attachment to trolley
- Material: Inox

<b>Art. No.</b>	64.746.081	1 pc. dispenser for MediCups ECO
	64.746.077	1 pc. dispenser for MediCups Light
	64.746.071	1 pc. dispenser for MediCups reusable



**Description** **Dispenser for lids for MediCups**

- Practical and hygienically storage container
- With Inox wall bracket
- Separate opening for the direct removal of individual lids
- Dimensions: 195x185x234 mm

<b>Art. No.</b>	64.747	1 pc. dispenser
-----------------	--------	-----------------



**Description** **Dish washer basket for MediCups reusable**

- Inox dish washer basket
- With space for 22 MediCups reusable or 18 inlay-dishes
- Also available with two inserts
- Dimensions: 415x90x70 mm

<b>Art. No.</b>	910.71.1	1 pc. dish washer basket with insert for MediCups
	910.66.1	1 pc. dish washer basket with insert for inlay-dishes
	910.71.66.1	1 pc. dish washer basket with two inserts
	910.00.1	1 pc. dish washer basket without inserts
	910.07.1	1 pc. insert for MediCups
	910.06.1	1 pc. insert for inlay-dishes

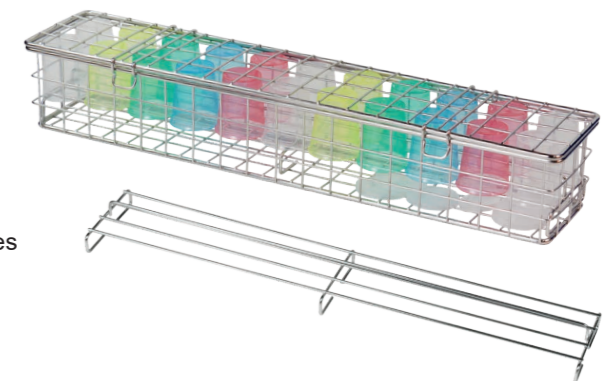

# WIEGAND® blister trolleys

The Wiegand blister trolleys were configured together with specialists to suit the processes. The medication process with blistered medications requires certain working aids that make the process more efficient. The trolleys were equipped according to the needs of the professionals and can ideally support the work processes.

## Wiegand's blister trolleys fulfil important criteria:

- Space-saving, hygienic and safe storage of medicines blistered in blister rolls
- Storage possibilities for additional medications and supplementary material
- Efficient, safe distribution and dispensing
- Time saving for the nursing staff, due to reduction of walking distances



## Trolley for storage and distribution of card blisters

The Wiegand trolleys are also suitable for supporting medication processes that are implemented with blister cards. Thanks to the FlexLine system, it is possible to respond to individual needs and adapt the trolley.

Contact us for an individual consultation to configure the ideal trolley for your work process.



# WIEGAND® FlexLine system

To tailor the blister trolley exactly to your needs, Wiegand offers you a high level of flexibility with the FlexLine system. Blister trolleys, like all other trolleys from Wiegand, can be individually configured thanks to our wide range of accessories and optimally adapted to your requirement.

## Different variations available

- Wiegand blister trolleys are available in two widths: 45cm or 60cm
- Side panels or extraction frames
- Laterally extendable work surface
- Additional shelves as storage space
- Various locking systems available
- Can be equipped with various accessories

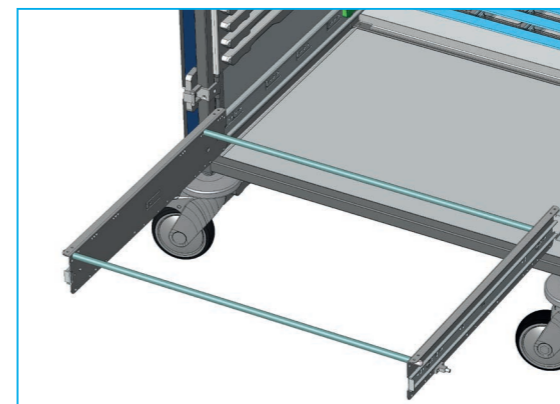

Extraction frames for the fixed use of modules in the trolley

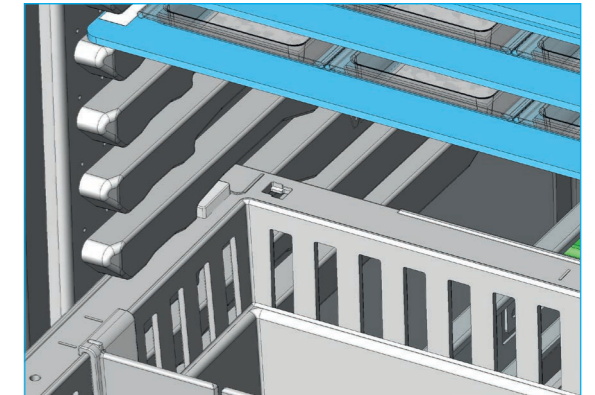

Side panels allow more flexible use of the trolley

## Trolley colours

Whether you want to work with uniform colour codes or follow a specific furnishing concept - Wiegand offers you a diverse selection of trolley colours. The fronts of the drawers and doors are available in the following 10 standard colours at no extra charge:



0717 Atlantic



0718 Arctis



0024 Vivo



0725 Yellow-green



2124 Camomilla



0010 Mango



0011 Mandarin



0067 Red



0021 Mona Lisa



0742 White

# The most popular blister trolleys

## Blister trolley 20 residents

- 45 cm wide blister trolley with side panels
- Suitable for FlexModul trays 450x400x100 mm
- Space for up to six FlexModul trays
- Door made of hygienic and robust high pressure laminate
- Laterally extendable work surface
- Can be supplemented with the following accessories: Holder for MediCups dispenser, risk waste container, waste bag container, disinfectant dispenser and glove holder

Trolley-ID: B20.02002

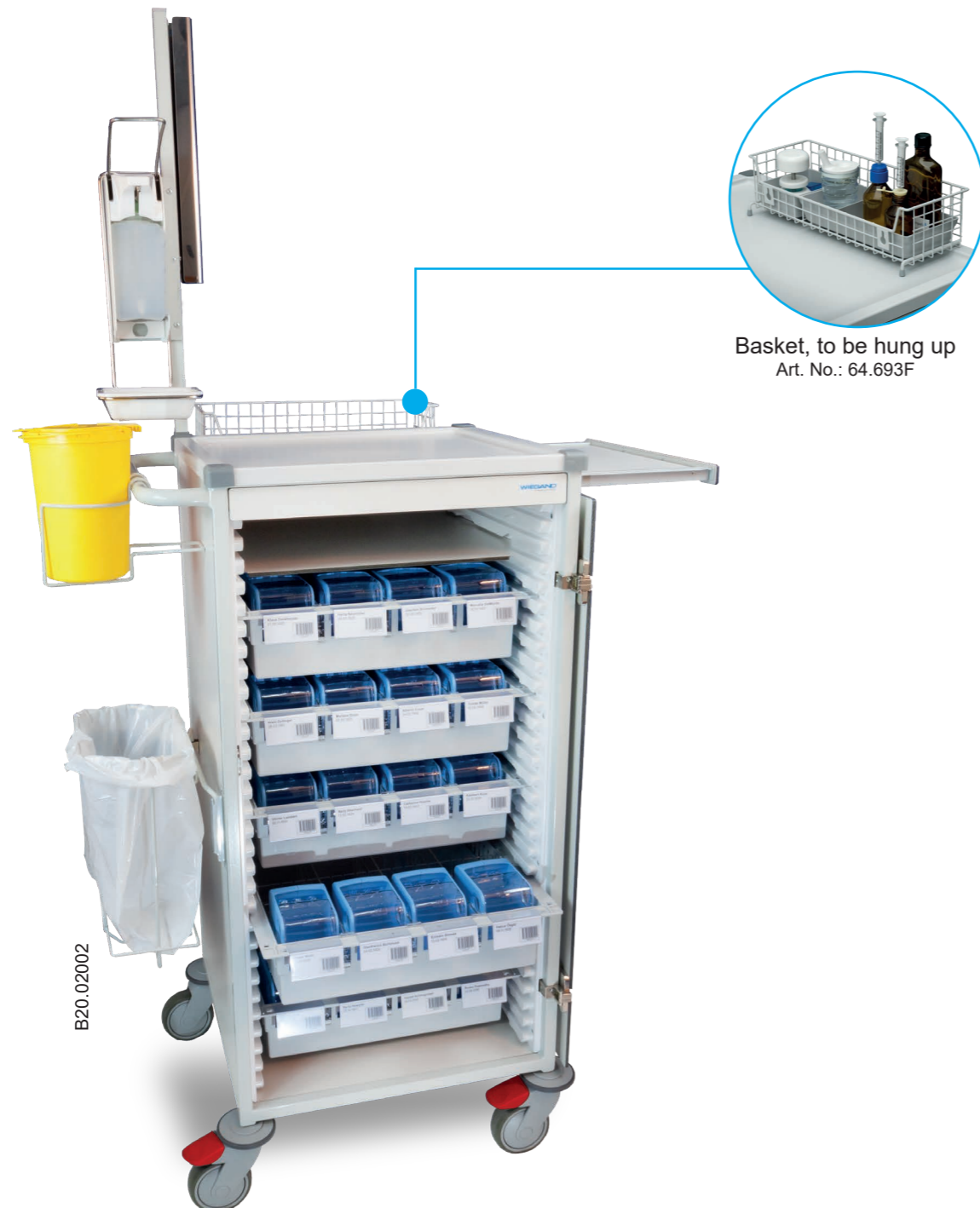

## Blister trolley 24 residents

- 45 cm wide blister trolley with extraction frames
- Suitable for FlexModul trays 450x400x100 mm
- Space for up to six FlexModul trays
- Door made of hygienic and robust high pressure laminate
- Laterally extendable work surface
- Can be supplemented with the following accessories: Holder for MediCups dispenser, risk waste container, waste bag container, disinfectant dispenser and glove holder

Trolley-ID: B20.02001





## Blister trolley 30 residents

- 60 cm wide blister trolley with side panels
- Suitable for FlexModul trays 600x400x100 mm
- Space for up to six FlexModul trays
- Shelf for additional storage space or distribution tray shelf
- Door made of hygienic and robust high pressure laminate
- Laterally extendable work surface
- Can be supplemented with the following accessories: Holder for MediCups dispenser, risk waste container, waste bag container, disinfectant dispenser and glove holder

Trolley-ID: B20.02005



## Blister trolley 30 residents

- 60 cm wide blister trolley with extraction frames
- Suitable for FlexModul trays 600x400x100 mm
- Shelf for additional storage space or distribution tray shelf
- Space up to five FlexModul trays
- Door made of hygienic and robust high pressure laminate
- Laterally extendable work surface
- Can be supplemented with the following accessories: Holder for MediCups dispenser, risk waste container, waste bag container, disinfectant dispenser and glove holder

Trolley-ID: B20.02004



## Blister trolley 36 residents

- 60 cm wide blister trolley with extraction frames
- Suitable for FlexModul trays 600x400x100 mm
- Space for up to six FlexModul trays
- Door made of hygienic and robust high pressure laminate
- Laterally extendable work surface
- Can be supplemented with the following accessories: Holder for MediCups dispenser, risk waste container, waste bag container, disinfectant dispenser and glove holder

Trolley-ID: B20.02003



Dispenser for MediCups



## FlexLine accessories

Wiegand offers you a selection of accessories which have been defined together with nursing professionals and ideally support the medication process with blistered medicines.

**Description** Lateral pull-out frame, with inserted tray

- Additional work surface
- Load up to 15 kg

**Article No.** 3440.2F Pull-out frame incl. tray



**Description** Holder with dispenser for disinfectant

- Also available without drainer

**Article No.** OP1416000 Disinfectant dispenser  
64.263800 Drainer



**Description** Holder for hand gloves box Alu, adjustable

- Practical glove holder for all popular glove packs

**Article No.** 64.711R-Alu Holder for hand gloves box right  
64.711L-Alu Holder for hand gloves box left



**Description** Holder with risk waste container

- Risk waste containers are available in two sizes

**Article No.** 64.679-0.5 Risk waste container 0.5 Liter  
64.679-2.0 Risk waste container 2 Liter  
64.743 Holder for risk waste container 0.5 Litres  
64.742 Holder for risk waste container 2 Litres



**Description** Waste bag holder

- with mounting / spring catch or fixed mounted available

**Article No.** 64.609F Waste bag holder large, swivelling (32x19x32cm)  
64.610 Waste bag holder large, fix mounted (32x19x32cm)



**Description** Waste bag holder, Inox

- fix mounted

**Article No.** 64.752 Waste bag holder Inox (24x17x33cm)



**Description** FlexModul tray, light grey, 450x400x100 mm

- Openwork tray, divisible

**Article No.** 4540.210 Tray

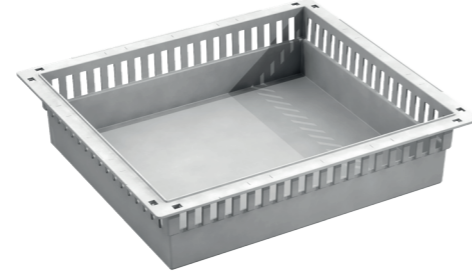

**Description** Subdivision set Acryl for FlexModul tray 4540.210

- Ideal for storing directly in the trolley BlisterBoxes, additional and reserve medications

**Article No.** 4540.210-D2 Subdivision set

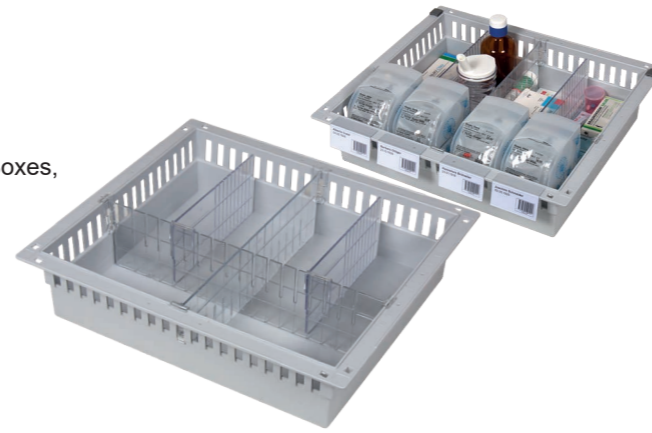

**Description** FlexModul tray, light grey, 600x400x100 mm

- Openwork tray, divisible

**Article No.** 6040.210 Tray



**Description** Subdivision set Acryl for FlexModul tray 6040.210

- Ideal for storing directly in the trolley BlisterBoxes, additional and reserve medications

**Article No.** 6040.210-D2 Subdivision set

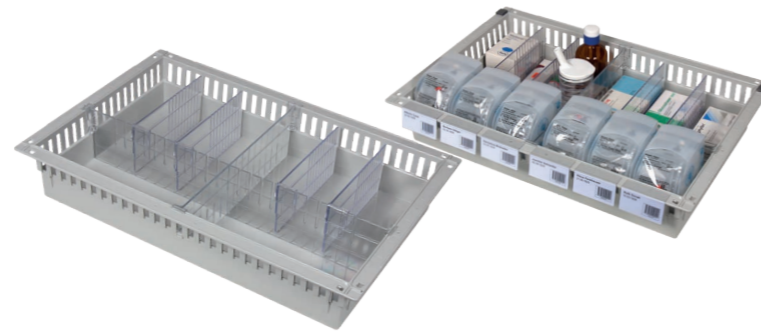

**Description** Holder for blister bags or labels

- Suitable for attaching tube blisters
- Pluggable on WIEGAND distribution trays, FlexModul trays/baskets
- Dimensions: 75x40 mm

**Article No.** 500.240XO.075 1 holder for blister bags or labels



Solutions for blistered medications

## Locking systems for your Wiegand trolley

To safeguard your materials we offer various locking systems. Locking systems are usually chosen on the basis of a company-wide locking plan. We will be happy to help you choose a suitable system.

**Description** Preparation for digital half cylinder Euro profile, 30 mm

- Central locking for trolley
- Preparation for on-site cylinder mounting in drawer side panel or door

**Article No.** 45-1-L-VDigiZ



**Description** KitLock

- Electronic combination lock

**Article No.** KL1000\*



**Description** KABA 8 lock cylinder

- Lock cylinder with bolt
- Bolt for front panel, door or side panel

**Article No.** 1061.08  
**Alternative** 1031.20 (The precondition is a locking plan)



## Cabinet for the storage of medicines and consumables

The storage of medicines and consumables in cabinets can - depending on the structural conditions - be used efficiently and offers various advantages for the organisation of the medication process. Our expert staff will accompany you on the way from planning to installation and will be at your side as a partner.





### Efficient organisation ensures order in the medicine cabinets

Arrange your medicine cabinet in a space-saving and clear way. You can store the blister packet strips in the practical and hygienic BlisterBoxes and place the additional and reserve medication in FlexModul trays or TRESTON containers. Choose the ideal solution for your medication process.



### TRESTON container

<b>Description</b>	<b>TRESTON container</b>
	• 1 front label incl. label protection included in the scope of delivery
<b>Art. No.</b>	3010-1 1 pc. TRESTON container, 92x300x82 mm
<b>Accessories</b>	10-D Divider 06-E-20 Label for divider, 20 pcs. 10-E-20 Front label, 20 pcs. 10-S-15 Protection for front label, 15 pcs.



<b>Description</b>	<b>TRESTON container</b>
	• 1 front label incl. label protection included in the scope of delivery
<b>Art. No.</b>	3015-1 1 pc. TRESTON container, 132x300x100
<b>Accessories</b>	15-D Divider 06-E-20 Label for divider, 20 pcs. 15-E-20 Front label, 20 pcs. 15-S-15 Protection for front label, 15 pcs.



<b>Description</b>	<b>TRESTON container</b>
	• 1 front label incl. label protection included in the scope of delivery
<b>Art. No.</b>	3020-1 1 pc. TRESTON container, 186x300x82 mm
<b>Accessories</b>	20-D Divider 06-E-20 Label for divider, 20 pcs. 20-E-20 Front label, 20 pcs. 20-S-15 Protection for front label, 15 pcs.



<b>Description</b>	<b>TRESTON container</b>
	• 1 front label incl. label protection included in the scope of delivery
<b>Art. No.</b>	4010-1 1 pc. TRESTON container, 92x400x82 mm
<b>Accessories</b>	10-D Divider 06-E-20 Label for divider, 20 pcs. 10-E-20 Front label, 20 pcs. 10-S-15 Protection for front label, 15 pcs.



<b>Description</b>	<b>TRESTON container</b>
	• 1 front label incl. label protection included in the scope of delivery
<b>Art. No.</b>	4015-1 1 pc. TRESTON container, 132x400x100 mm
<b>Accessories</b>	15-D Divider 06-E-20 Label for divider, 20 pcs. 15-E-20 Front label, 20 pcs. 15-S-15 Protection for front label, 15 pcs.



<b>Description</b>	<b>TRESTON container</b>
	• 1 front label incl. label protection included in the scope of delivery
<b>Art. No.</b>	4020-1 1 pc. TRESTON container, 186x400x82 mm
<b>Accessories</b>	20-D Divider 06-E-20 Label for divider, 20 pcs. 20-E-20 Front label, 20 pcs. 20-S-15 Protection for front label, 15 pcs.





## Weekly systems from WIEGAND<sup>®</sup>

**Weekly trays or weekly containers for a single resident or storage trays for a whole group of patients**

Wiegand offers you an extensive range of weekly systems which can be used individually. Store Medi-Dispensers practically on trays or in containers, depending on the space available. Wiegand solutions adapt to your work processes and offer many tools to improve patient safety.

### Wiegand AG

Schlosserstrasse 5  
CH-8180 Bülach  
Tel.: +41 44 872 74 74  
wiegand@wiegand.ch  
www.wiegand.ch